



# Electric Forklift

[www.maxforklift.com](http://www.maxforklift.com)

A series 4-wheel 1.5-3.5t

A series reach truck 1.6-2.5t

M series 3-wheel forklift 1.6-2t

M series rear drive 3-wheel forklift 1.6t



Electric Forklift



Hyster-Yale Maximal Forklift (Zhejiang) Co., Ltd

**Address** No.1, jinxin Road, Lushan Industrial area, Fuyang, Zhejiang China

**Tel** 0086-571-28001566

0086-571-28935028

0086-571-28979902

**Fax** 0086-571-28001569

**Email**

For sales

[info@maxforklift.com](mailto:info@maxforklift.com)

For spare parts

[parts@maxforklift.com](mailto:parts@maxforklift.com)

All rights reserved.

If any doubt, please contact us.



# maximal

MAXIMAL FAMILY



*We work for maximal*



# Maximal Company Introduction



Established in Feb. 2006, Hyster-Yale Maximal Forklift (zhcjiang) Co., Ltd, is located in Lushan Industry Area with convenient transportation. Maximal specializes in material handling equipment designing and manufacturing.

Maximal Company total floor area is 133,334㎡, investment RMB420 million, factory designed production capacity is 30000 units per year.

Currently Maximal employs 500 staffs, with more than 230 professional and technical personnel, more than 70 Technical R&D personnel. Maximal gained 7 national invention patents, more than 70 utility model and appearance patents.

Maximal owns advanced parts processing center, robot welding equipments, parts automatic hoist conveyor lines, coating lines, assembly lines, forklifts performance test lines, parts test-bed and ERP information management system.

Maximal current product range covers 4 series, including 1.5-compact12T industrial forklift, 1.8-5.0T rough terrain forklift, 13.5-32.0T heavy duty forklift, siade loader forklift& Port machinery and warehouse equipment.

Maximal forklifts received strong public recognition for their modern and striking appearance, high production quality, safety standard and low cost of operation.

At present, Maximal products sales have covered all provinces in domestic market, exported to over 100 countries and areas. Maximal takes "technology innovation, promoting products structure, improving product quality and service" as the belief, takes internationalization, professionalization and green environmental protection as mission, to build Maximal into the most respectable forklift brand.

## Current products consist of:

### M series:

- 1.5-32T/3000-64,000LB capacity diesel forklifts.
- 1.5-7T/3000-14,000LB capacity gasoline/LPG forklifts.
- 4-5T/8000-10,000LB capacity 4-wheel electric forklifts.
- 1.6-2T/3200-4000LB capacity 3-wheel electric forklifts.
- 0.7-1.5T/1400-3000LB capacity VNA truck.
- 1.6T/3200LB capacity Rear drive 3-wheel electric forklifts.
- 2.5T/4000-5000LB capacity dual-drive 4-wheel electric forklifts.
- 2.5T/4000-5000LB capacity cushion tyre forklifts.
- 1.3-3T/2600-6000LB capacity Omni-Directional electric forklifts.

### A series:

- 2.5-3.5T/4000-7000LB capacity diesel and gasoline/LPG forklifts.

- 1.5-3.5T/3000-7000LB capacity 4-wheel electric forklifts.

- 1.6-2.5T/3200-5000LB capacity electric reach truck.

### Rough Terrain:

- 1.8-3.5T/3600-7000LB capacity compact 4WD rough terrain forklifts.
- 2.5-3.5T/5000-7000LB capacity 4WD rough terrain forklifts.
- 1.8-5.0T/3600-10,000LB capacity 2WD rough terrain forklifts.

### Port Machinery:

- 9T/18,000LB capacity empty container handler.
- 45T/90,000LB capacity reach stacker.

### Side Loader Forklift:

- 3.5T-4.5T/7000-9900LB capacity side loader forklifts.

## A series 4-wheel electric forklift

Ranges from 1.5-3.5t, with ZAPI ACE2 controller of horizontally layout, integrated transmission and axle, L-type pump motor. A series model design concept is "Engineering for driver", with more safety, more comfort, and every small detail carefully designed prepared for the driver.



Classification of After-sales Service

## A series reach truck

Can be provided with stand operation model and sit operation model, load capacity ranges from 1.6-2.5t, not only enjoys excellent performance, but also has economical price. It is equipped with AC system, drive motor 6.5kw and lifting motor 11kw, hydraulic parking brake, electronic steering, compact structure, small size, small turning radius and excellent maneuvering performance.



24-hour fast reply on trucks and parts claims

## M series 3-wheel electric forklift

Ranges from 1.6-2t, is a series of products developed and manufactured to satisfy the market demands, this 3-wheel type design is the perfect machine for dock operations loading & unloading trucks & trailers. The compact and streamlined body can maneuver in close spaces and narrow aisle applications eliminating the need for the more expensive reach machines.

## M series rear drive 3-wheel electric forklift

Designed load capacity 1.6t, is a type of super economic forklift, with ZAPI ACE2 Controller, rear drive with one pc of driving motor, battery capacity 48V425AH, one mini rear steering wheel makes the turning radius smaller, with cost-effective, stable, working flexibility, high interchangeability etc. high performance, popular welcomed by market at home and abroad.

## Classification of After-sales Service

Classification of After-sales Service classifies customer claims into 3 classes, Warranty 1(W1), Warranty 2(W2), Warranty 3(W3). Different claim class has different after-sales procedures which aims to increase service quality.





## A SERIES 1.5-3.5t 4-wheel electric forklift/Li-Ion battery forklift

Specification	1 Model		FBA15-JZ	FBA18-JZ	FBA20-JZ	FBA25-JZ	FBA30-JZ	FBA35-JZ		
	2	Rated capacity	kg	1500	1800	2000	2500	3000	3500	
3	Load centre	mm	500							
4	Lifting height	mm	3000							
5	Free lifting height	mm	135	140			165			
6	Fork size	T×W×L	35×100×920		40×122×1070		45×125×1070	50×130×1070		
7	Tilting angle	F/R (α°/β°)	5/10							
Dimensions	8	Length (to forkface)	mm	2073	2118	2286.5		2548	2639	
	9	Width	mm	1120		1285		1285	1365	
	10	Height when mast lowered	mm	2000		2015		2045	2120	
	11	Height when mast extended	mm	3980		3990		4100	4140	
	12	Height to safeguard	mm	2135		2152		2152	2138	
	13	Turning radius	Min.	mm	1965		2080		2349	2405
	14	Front overhang/rear overhang	mm	410/317		454/390		475/402	495.5/453.5	
	15	Tread	F/R	mm	955/920		1058/960		1065/980	1124/1010
	16	Ground clearance	Min.	mm	105		95		110	83
	17	Wheelbase	mm	1380		1485		1670	1690	
	18	Fork spread	Min./Max.	mm	250/890		250/1000		250/1060	
	Performance	19	Working aisle width with pallet(Ast)*	mm	1000×1200 crossways		3541		3732	4025
20			mm	800×1200 lengthways		3741		3932	4225	4301
21		Speed	Travel(Laden)	km/h	15		15		15	
22			Travel(Unladen)	km/h	16		16		16	
23			lifting (laden/unladen)	mm/s	290/440		280/440		280/400	280/384
24			lowering (laden/unladen)	mm/s	410/410		470/430		400/315	
25	Gradeability	Laden	%	15		15		15		
26		Unladen	%	15		15		15		
27	Service weight	Include battery box	kg	2950	3230	3930	4100	4750	5253	
28	Tyre	Front×2		6.00-9 10PR		23×9-10 16PR		23×9-10 16PR	23×10-12	
29		Rear×2		5.00-8 8PR		18×7-8-14PR		18×7-8-14PR	200/50-10	
Driven	30	Motor	Driven motor	kw	K6.5		K8.5		K11.5	
	31		Pump motor	kw	K8.6		K11		K15	
	32	Battery	Standard(Optional)	V/Ah	48/420		48/600		80/500	
	33	Controller	Type		AC	AC	AC	AC	AC	AC
	34		Manufacturer		ZAPI	ZAPI	ZAPI	ZAPI	ZAPI	ZAPI
	35	Operating pressure for attachment	Mpa	14.5			17.5			

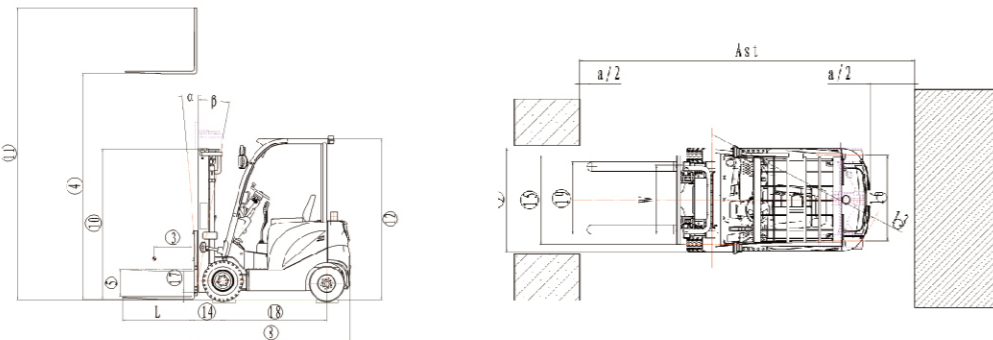

## A SERIES 1.5-1.8t forklift mast

Type	Model	Max. fork height	Overall height						Free lift		Front Overhang		Tilt range		Capacity	
			Lowered		Extended				Without backrest	with backrest	1.5t	1.8t	FWD	BWD	load capacity at 500mm	
			1.5t	1.8t	Without backrest		With backrest								Single tyre	
			mm	mm	mm	mm	mm	mm	mm	mm	mm	mm	Deg	Deg	kg	kg
wide view 2-stage mast	M200	2000	1500	1500	2513	2513	2984	2984	135	135	410	410	5	10	1500	1800
	M250	2500	1750	1750	3013	3013	3484	3484	135	135	410	410	5	10	1500	1800
	M300	3000	2000	2000	3513	3513	3984	3984	135	135	410	410	5	10	1500	1800
	M330	3300	2150	2150	3813	3813	4284	4284	135	135	410	410	5	10	1500	1800
	M350	3500	2250	2250	4013	4013	4484	4484	135	135	410	410	5	10	1500	1800
	M370	3700	2350	2350	4213	4213	4684	4684	135	135	410	410	5	10	1460	1760
	M400	4000	2550	2550	4513	4513	4984	4984	135	135	410	410	5	10	1400	1700
	M425	4250	2675	2675	4763	4763	5234	5234	135	135	410	410	5	6	1400	1600
	M450	4500	2800	2800	5013	5013	5484	5484	135	135	410	410	5	6	1300	1500
	M500	5000	3050	3050	5513	5513	5984	5984	135	135	410	410	5	6	1000	1100
full free 2-stage mast	M550	5500	3350	3350	6013	6013	6484	6484	135	135	410	410	3	6	800	1000
	M600	6000	3600	3600	6513	6513	6984	6984	135	135	410	410	3	6	500	600
	FM250	2500	1750	1750	3013	3013	3484	3484	1165	780	410	410	5	10	1500	1800
	FM300	3000	2000	2000	3513	3513	3984	3984	1415	1030	410	410	5	10	1500	1800
	FM330	3300	2150	2150	3813	3813	4284	4284	1565	1180	410	410	5	10	1500	1800
	FM350	3500	2250	2250	4013	4013	4484	4484	1665	1280	410	410	5	10	1500	1800
	FM370	3700	2350	2350	4213	4213	4684	4684	1765	1380	410	410	5	10	1410	1710
	FM400	4000	2550	2550	4513	4513	4984	4984	1965	1580	410	410	5	6	1350	1650
Full free 3-stage mast	TFM435	4350	2000	2000	4863	4863	5334	5334	1420	1030	410	410	5	6	1250	1500
	TFM450	4500	2050	2050	5013	5013	5484	5484	1470	1080	410	410	5	6	1200	1400
	TFM480	4800	2150	2150	5313	5313	5784	5784	1570	1180	410	410	5	6	1100	1200
	TFM500	5000	2250	2250	5513	5513	5984	5984	1670	1280	410	410	5	6	950	1050
	TFM540	5400	2375	2375	5913	5913	6384	6384	1795	1405	410	410	3	6	750	850
	TFM600	6000	2610	2610	6513	6513	6984	6984	2020	1630	410	410	3	6	450	550
	TFM650	6500	2805	2805	7013	7013	7484	7484	2235	1845	410	410	3	6	250	300



## A SERIES 2-2.5t forklift mast

Type	Model	Max. fork height	Overall height						Free lift		Front Overhang		Tilt range		Capacity	
			Lowered		Extended				Without backrest	with backrest	2t	2.5t	FWD	BWD	load capacity at 500mm	
			2t	2.5t	Without backrest		With backrest								Single tyre	
			mm	mm	mm	mm	mm	mm	mm	mm	mm	mm	Deg	Deg	kg	kg
wide view 2-stage mast	M250	2500	1765	1765	3115	3115	3517	3517	140	140	454	454	5	10	2000	2500
	M300	3000	2015	2015	3616	3616	4017	4017	140	140	454	454	5	10	2000	2500
	M330	3300	2165	2165	3916	3916	4317	4317	140	140	454	454	5	10	2000	2500
	M350	3500	2265	2265	4115	4115	4517	4517	140	140	454	454	5	10	2000	2500
	M370	3700	2365	2365	4315	4315	4717	4717	140	140	454	454	5	10	2000	2500
	M400	4000	2565	2565	4616	4616	5017	5017	140	140	454	454	5	10	2000	2500
	M450	4500	2815	2815	5115	5115	5517	5517	140	140	454	454	5	6	1600	2100
	M500	5000	3065	3065	5615	5615	6017	6017	140	140	454	454	5	6	1200	1600
	M550	5500	3365	3365	6115	6115	6517	6517	140	140	454	454	3	6	950	1200
	M600	6000	3615	3615	6616	6616	7017	7017	140	140	454	454	3	6	800	900
full free 2-stage mast	FM250	2500	1765	1765	3115	3115	3517	3517	1170	770	477	477	5	10	2000	2500
	FM300	3000	2015	2015	3615	3615	4017	4017	1420	1020	477	477	5	10	2000	2500
	FM330	3300	2165	2165	3915	3915	4317	4317	1570	1170	477	477	5	10	2000	2500
	FM350	3500	2265	2265	4115	4115	4517	4517	1670	1270	477	477	5	10	2000	2500
	FM370	3700	2365	2365	4315	4315	4717	4717	1770	1370	477	477	5	6	2000	2500
	FM400	4000	2565	2565	4615	4615	5017	5017	1970	1570	477	477	5	6	2000	2500
	TFM435	4350	2015	2015	5021	5021	5366	5366	1390	990	490	490	5	6	1750	2200
	TFM450	4500	2065	2065	5171	5171	5516	5516	1440	1040	490	490	5	6	1600	2000
Full free 3-stage mast	TFM480	4800	2165	2165	5417	5417	5816	5816	1540	1140	490	490	5	6	1250	1700
	TFM500	5000	2265	2265	5617	5617	6016	6016	1640	1240	490	490	5	6	1100	1500
	TFM550	5500	2390	2390	6117	6117	6516	6516	1765	1400	490	490	3	6	900	1200
	TFM600	6000	2615	2615	6617	6617	7016	7016	1990	1590	490	490	3	6	700	800
	TFM650	6500	2840	2840	7171	7171	7516	7516	2205	1805	490	490	3	6	400	500

## A SERIES 3-3.5t forklift mast

Type	Model	Max. fork height	Overall height						Free lift				Front Overhang		Tilt range		Capacity	
			Lowered		Extended				Without backrest		with backrest		3t	3.5t	FWD	BWD	load capacity at 500mm	
			3t	3.5t	Without backrest		With backrest		3t	3.5t	Single tyre							
					mm	mm	mm	mm			mm	mm	mm	mm	kg	kg		
wide view 2-stage mast	M250	2500	1795	1870	3140	3210	3640	3640	165	170	165	170	475	505	5	10	3000	3500
	M300	3000	2045	2120	3640	3710	4140	4140	165	170	165	170	475	505	5	10	3000	3500
	M330	3300	2195	2270	3940	4010	4440	4440	165	170	165	170	475	505	5	10	3000	3500
	M350	3500	2295	2370	4140	4210	4640	4640	165	170	165	170	475	505	5	10	3000	3500
	M370	3700	2395	2470	4340	4410	4840	4840	165	170	165	170	475	505	5	10	3000	3500
	M400	4000	2595	2670	4640	4710	5140	5140	165	170	165	170	475	505	5	10	2850	3300
	M450	4500	2845	2920	5140	5210	5640	5640	165	170	165	170	475	505	5	6	2550	2900
	M500	5000	3095	3170	5640	5710	6140	6140	165	170	165	170	475	505	5	6	2100	2400
full free 2-stage mast	FM250	2500	1795	1870	3140	3200	3640	3600	1140	1165	685	750	490	505	5	10	3000	3500
	FM300	3000	2045	2120	3640	3700	4140	4100	1390	1415	935	1000	490	505	5	10	3000	3500
	FM330	3300	2195	2270	3940	4000	4440	4400	1540	1565	1085	1150	490	505	5	10	3000	3500
	FM350	3500	2295	2370	4140	4200	4640	4600	1640	1665	1185	1250	490	505	5	10	3000	3500
	FM370	3700	2395	2470	4340	4400	4840	4800	1740	1765	1285	1350	490	505	5	10	3000	3500
	FM400	4000	2595	2670	4640	4700	5140	5100	1940	1965	1485	1550	490	505	5	10	2850	3300
Full free 3-stage mast	TFM435	4350	2045	2120	5015	5100	5490	5500	1460	1460	925	925	500	522	5	6	2800	3100
	TFM450	4500	2095	2170	5165	5250	5640	5650	1510	1510	975	975	500	522	5	6	2500	2800
	TFM480	4800	2195	2270	5465	5550	5940	5950	1610	1610	1075	1075	500	522	5	6	2250	2500
	TFM500	5000	2295	2370	5665	5750	6140	6150	1710	1710	1175	1175	500	522	5	6	2100	2300
	TFM540	5400	2420	2435	6065	6150	6540	6550	1835	1835	1300	1300	500	522	3	6	1650	1800
	TFM600	6000	2645	2720	6665	6750	7140	7150	2060	2060	1525	1525	500	522	3	6	1200	1300
	TFM650	6500	2860	2935	7165	7250	7640	7650	2275	2275	1740	1740	500	522	3	6	700	800

Li-Ion battery is available for 4-wheel electric forklift

Main advantages:

- Compact body**  
energy density more than 120W · h/kg
- Operating temperature**  
Charge: 0~45 ℃  
Discharge: -20~60 ℃
- Long service life**  
>2500 times (80% remaining capacity), the service life more than 5 years or 10000 hours
- 5 years guarantee**
- High charge efficiency**  
>97%
- Impact of environment**  
zero pollution
- Fast charging**  
2-4hours quick charge, no memory effect.
- Control system**  
With BMS management system, it can monitor the current, voltage, temperature, SOC and other conditions of each battery pack. With self-protection.
- High safety and reliability**
- Maintenance free**

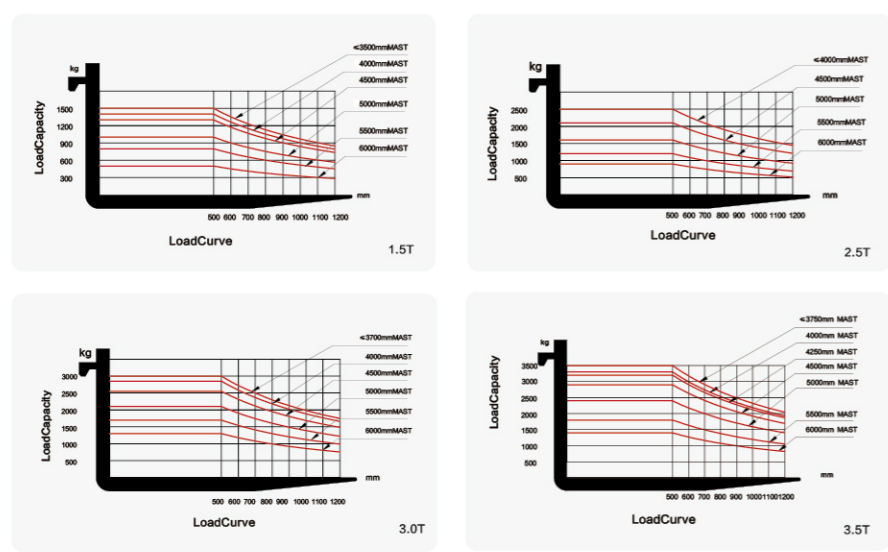

### A SERIES 1.6-2.5t reach truck

Specification	1	Model	FBREA16-JI	FBREA20-JI	FBREA25-JI	
			2	Power	Electric	
3	Operator type	Sit				
4	Rated load capacity	Q(kg)	1600	2000	2500	
5	Rated lift height	h3(mm)	3000	3000	3000	
6	Load centre	C(mm)	600	600	600	
7	Fork carriage tilt (Forward/Backward)	α/β(deg)	2°/4°	2°/4°	2°/4°	
8	Travel speed (Laden/Unladen)	(km/h)	10.0/11.0	10.0/11.0	10.0/10.5	
9	Lifting speed(Laden)	(mm/s)	290	280	260	
10	Max. gradeability(Laden)	(%)	10	10	10	
11	Min. turning radius	Wa(mm)	1690	1750	1850	
12	Reach distance	X(mm)	570	660	660	
13	Wheelbase	Y(mm)	1440	1500	1600	
14	Service brake		Hyd	Hyd	Hyd	
Dimensions	15	Overall length	l1(mm)	2381	2381	2480
	16	Main body length	l7(mm)	1852	1942	2042
	17	Rear body length	l2(mm)	1311	1311	1410
	18	Overall width	b1(mm)	1270	1270	1270
	19	Height of mast,lowered	h1(mm)	2090	2090	2130
	20	Free lift height	h2(mm)	330	330	330
	21	Height of mast,extended	h4(mm)	3895	3895	3875
	22	Height of overhead guard	h5(mm)	2100	2100	2100
	23	Fork dimensions(T×W×L)	(mm)	40×122×1070	40×122×1070	40×122×1070
	24	Fork regulating range(Min/Max)	(mm)	270/714	270/714	270/714
	25	Min. ground clearance	h6(mm)	85	85	85
	26	Min. aisle width with pallet (1200L×1000W)	Ast1(mm)	2750	2770	2870
27	Min. aisle width with pallet (800L×1200W)	Ast2(mm)	2800	2810	2910	
28	Service weight	(kg)	2860	3070	3520	
Tyre	29	Drive motor	(Kw)	6.5	6.5	6.5
	30	Lift motor	(Kw)	11	11	11
	31	Battery:Voltage/capacity (5h)standard (option)	(V/Ah)	48/450	48/450	48/600
	32	Tyres		Polyurethane Solid tyre		
	33	Size of front tyre	(mm)	∅ 285×108		∅ 343×108
Other	34	Size of driven tyre	(mm)	∅ 343×140		
	35	Size of balancing tyre	(mm)	1132		
	36	Turning system		Electric		
	37	Speed control system		Inmotion		

Reach truck stand operation model will be lanuched in 2019

### A SERIES 1.6-2.5t reach truck mast

	Type	Max. fork height	Mast height									Free lift height						Capacity					
			Overall height (mm) -lowered			Lifting height						without bracket			with bracket			Front overhang			Load center (600mm)		
			1.6T	2.0T	2.5T	Without backrest			With backrest			1.6T	2.0T	2.5T	1.6T	2.0T	2.5T	1.6T	2.0T	2.5T	1.6T	2.0T	2.5T
						mm	mm	mm	mm	mm	mm												
2-stage	RM300	3000	2090	2090	2130	3615	3615	3595	3895	3895	3875	330	330	330	330	330	330	191	221	220	1600	2000	2500
	RM360	3600	2390	2390	2430	4205	4205	4195	4485	4485	4475	330	330	330	330	330	330	191	221	220	1600	2000	2500
	RM380	3800	2490	2490	2530	4405	4405	4395	4685	4685	4675	330	330	330	330	330	330	191	221	220	1600	2000	2500
	RM400	4000	2640	2640	2680	4605	4605	4595	4885	4885	4875	330	330	330	330	330	330	191	221	220	1600	2000	2500
	RM420	4200	2740	2740	2780	4805	4805	4795	5085	5085	5075	330	330	330	330	330	330	191	221	220	1600	2000	2500
	RM450	4500	2890	2890	2930	5105	5105	5095	5385	5385	5375	330	330	330	330	330	330	191	221	220	1600	2000	2500
	RM480	4800	3040	3040	3080	5405	5405	5395	5685	5685	5675	330	330	330	330	330	330	191	221	220	1600	2000	2500
	RM500	5000	3140	3140	3180	5605	5605	5595	5885	5885	5875	330	330	330	330	330	330	191	221	220	1600	2000	2500
	RM550	5500	3440	3440	3480	6105	6105	6095	6385	6385	6375	330	330	330	330	330	330	191	221	220	1600	2000	2250
	RM600	6000	3690	3690	3730	6605	6605	6595	6885	6885	6875	330	330	330	330	330	330	191	221	220	1500	1800	2000
3-stage	RTFM400	4000	1915	1915	1950	4605	4605	4675	4885	4885	4880	1355	1355	1270	1030	1030	1060	191	221	220	1600	2000	2500
	RTFM420	4200	1980	1980	2015	4805	4805	4870	5085	5085	5075	1425	1425	1335	1095	1095	1125	191	221	220	1600	2000	2500
	RTFM450	4500	2080	2080	2115	5105	5105	5170	5385	5385	5375	1520	1520	1435	1195	1195	1230	191	221	220	1600	2000	2500
	RTFM480	4800	2180	2180	2215	5405	5405	5470	5685	5685	5675	1625	1625	1535	1295	1295	1330	191	221	220	1600	2000	2500
	RTFM500	5000	2300	2300	2315	5605	5605	5670	5885	5885	5875	1740	1740	1635	1410	1410	1430	191	221	220	1600	2000	2500
	RTFM520	5200	2365	2365	2385	5805	5805	5875	6085	6085	6080	1805	1805	1705	1480	1480	1495	191	221	220	1600	2000	2300
	RTFM560	5600	2500	2500	2515	6205	6205	6270	6485	6485	6475	1940	1940	1835	1610	1610	1630	191	221	220	1600	2000	2200
	RTFM600	6000	2630	2630	2650	6605	6605	6675	6885	6885	6880	2075	2075	1970	1745	1745	1760	191	221	220	1500	1850	2000
	RTFM620	6200	2700	2700	2715	6805	6805	6870	7085	7085	7075	2140	2140	2035	1810	1810	1830	191	221	220	1450	1800	1950
	RTFM660	6600	2880	2880	2900	7205	7205	7280	7485	7485	7485	2280	2280	2220	1995	1995	2015	191	221	220	1400	1700	1900
	RTFM700	7000	3015	3015	3035	7605	7605	7680	7885	7885	7885	2415	2415	2355	2130	2130	2145	191	221	220	1100	1400	1800
	RTFM720	7200	3080	3080	3100	7805	7805	7880	8085	8085	8085	2480	2480	2420	2195	2195	2215	191	221	220	1050	1300	1600
	RTFM750	7500	3180	3180	3200	8105	8105	8180	8385	8385	8385	2580	2580	2520	2295	2295	2315	191	221	220	1000	1200	1500
	RTFM800	8000	3350	3350	3370	8605	8605	8680	8885	8885	8885	2750	2750	2685	2460	2460	2480	191	221	220	800	1000	1300
	RTFM820	8200	/	3435	3435	/	8880	8880	/	9085	9085	/	2755	2755	/	2545	2545	/	221	220	/	950	1250
	RTFM850	8500	/	3535	3535	/	9180	9180	/	9385	9385	/	2855	2855	/	2645	2645	/	221	220	/	900	1200
	RTFM900	9000	/	3700	3700	/	9680	9680	/	9885	9885	/	3020	3020	/	2815	2815	/	221	220	/	800	1100
	RTFM920	9200	/	3770	3770	/	9880	9880	/	10085	10085	/	3085	3085	/	2880	2880	/	221	220	/	700	1000
RTFM950	9500	/	3870	3870	/	10180	10180	/	10385	10385	/	3185	3185	/	2980	2980	/	221	220	/	600	950	
RTFM1000	10000	/	4035	4035	/	10680	10680	/	10885	10885	/	3355	3355	/	3150	3150	/	221	220	/	500	800	

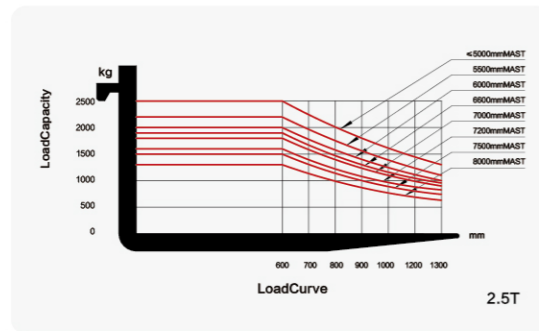
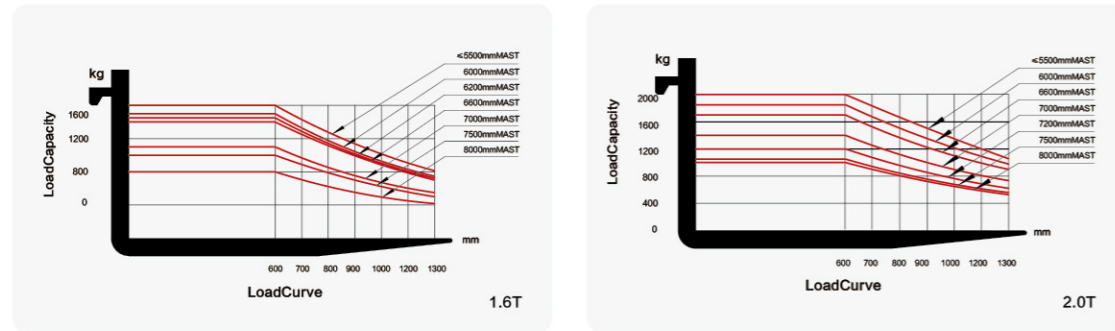

### M SERIES 1.6-2.0t 3-wheel electric forklift

Specification	Model		FB16S-MJZ	FB18S-MJZ	FB20S-MJZ	
	1	Model		FB16S-MJZ	FB18S-MJZ	FB20S-MJZ
2	Rated capacity	kg	1600	1800	2000	
3	Load centre	mm	500	500	500	
4	Lifting height	mm	3000	3000	3000	
5	Free lifting height	mm	0	0	0	
6	Fork size	T×W×L	35×100×920	35×100×920	35×100×920	
7	Tilting angle	F/R (α°/β°)	6.5°/6.5°	6.5°/6.5°	6.5°/6.5°	
Dimensions	8	Length (to forkface)	mm	1979	1979	2094
	9	Width	mm	1070	1070	1140
	10	Height when mast lowered	mm	1975	1975	1975
	11	Height when mast extended	mm	4010	4010	4010
	12	Height to safeguard	mm	1971	1971	2011
	13	Turning radius Min.	mm	1643	1643	1758
14	Front overhang	mm	371	371	371	
15	Tread F/R	mm	924/186	924/186	942/186	
16	Ground clearance Min.	mm	90	90	90	
17	Wheelbase	mm	1400	1400	1515	
18	Fork spread Min./Max.	mm	200/890	200/890	200/890	
19	Working aisle width with pallet(Ast)*	1000×1200 crossways	mm	3340	3340	3445
20		800×1200 lengthways	mm	3464	3464	3579
Performance	21	Travel(Laden)	km/h	13	13	13
	22	Travel(Unladen)	km/h	13	13	13
	23	Lifting(Laden)	mm/s	290	280	255
	24	Lifting(Unladen)	mm/s	445	435	435
	25	Gradeability Laden	%	15	15	15
	26	Gradeability Unladen	%	15	15	15
27	Service weight Include battery box	kg	3080	3140	3430	
28	Tyre Front×2		18×7-8	18×7-8	200/50-10	
29	Tyre Rear×2		15×4 <sup>1/2</sup> -8	15×4 <sup>1/2</sup> -8	15×4 <sup>1/2</sup> -8	
Driven	30	Motor Driven motor	kw	4×2	4×2	4×2
	31	Pump motor	kw	9.2	11	11
	32	Battery Standard(Optional)	V/Ah	48/500	48/500	48/620
	33	Controller Type		AC	AC	AC
	34	Controller Manufacturer		ZAPI	ZAPI	ZAPI
	35	Operating pressure for attachment	Mpa	14.5	14.5	17.5

**M SERIES** 1.6-2.0t 3-wheel electric forklift mast

Type	Model	Max. fork height mm	Overall height				Free lift		Front Overhang mm	Tilt range		Capacity		
			Lowered mm	Extended		Without backrest mm	with backrest mm	FWD Deg		BWD Deg	load capacity at 500mm			
				Without backrest mm	With backrest mm						Single tyre			
											1.6t kg	1.8t kg	2.0t kg	
2-stage mast	BM250	2500	1725	3010	3480	0	0	371	6.5	6.5	1600	1800	2000	
	BM270	2700	1825	3210	3680	0	0	371	6.5	6.5	1600	1800	2000	
	BM300	3000	1975	3510	4010	0	0	371	6.5	6.5	1600	1800	2000	
	BM330	3300	2125	3810	4280	0	0	371	6.5	6.5	1600	1800	2000	
	BM350	3500	2225	4010	4480	0	0	371	6.5	6.5	1600	1800	2000	
	BM370	3700	2325	4210	4680	0	0	371	6.5	6.5	1600	1800	2000	
	BM400	4000	2525	4510	4980	0	0	371	3.5	5	1600	1800	2000	
	BM425	4250	2650	4760	5280	0	0	371	3.5	5	1500	1700	1900	
	BM450	4500	2775	5025	5480	0	0	371	3.5	5	1400	1600	1800	
BM550	5500	3325	6025	6480	0	0	371	3.5	5	1150	1200	1300		
full free 2-stage mast	BFM250	2500	1725	3010	3465	1200	760	371	6.5	6.5	1600	1800	2000	
	BFM270	2700	1825	3210	3665	1300	860	371	6.5	6.5	1600	1800	2000	
	BFM300	3000	1975	3510	3965	1450	1010	371	6.5	6.5	1600	1800	2000	
	BFM330	3300	2125	3810	4265	1600	1160	371	6.5	6.5	1600	1800	2000	
	BFM350	3500	2225	4010	4465	1700	1260	371	6.5	6.5	1600	1800	2000	
	BFM370	3700	2325	4210	4665	1800	1360	371	6.5	6.5	1600	1800	2000	
Full free 3-stage mast	BTFM435	4350	1975	4860	5330	1425	995	371	3.5	5	1500	1700	1900	
	BTFM450	4500	2025	5010	5480	1475	1045	371	3.5	5	1400	1600	1800	
	BTFM480	4800	2125	5310	5780	1575	1145	371	3.5	5	1300	1500	1650	
	BTFM500	5000	2225	5510	5980	1675	1245	371	3.5	5	1250	1450	1500	
	BTFM550	5500	2390	6010	6480	1840	1410	371	3.5	5	1150	1200	1300	
	BTFM600	6000	2575	6510	6980	2025	1595	371	3.5	5	1050	1100	1200	
BTFM650	6500	2790	7010	7480	2205	1775	371	3.5	5	900	950	1000		

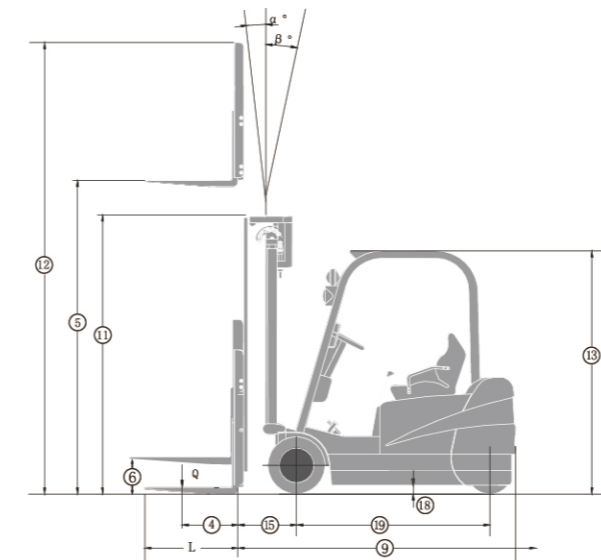

a=200 mm safety clearance  
 $AST=a+(14)+(15)+\sqrt{W^2+(B/2)^2}$

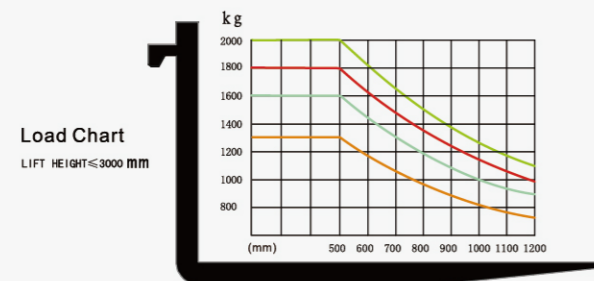
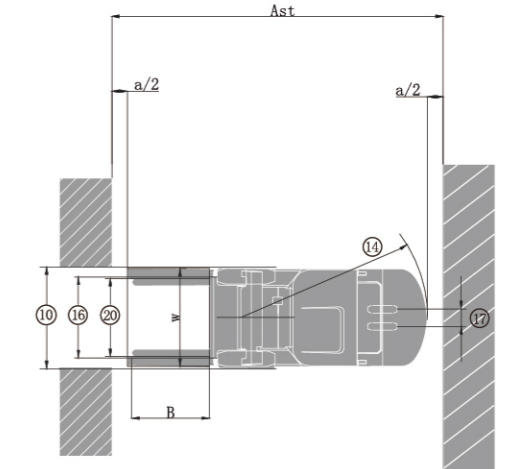



**M SERIES** 1.6t rear drive 3-wheel electric forklift mast

**M SERIES** 1.6t rear drive 3-wheel electric forklift

Specification	1		Model		FB16S-MHJZ			
		2		Power		Electric		
	3		Rated capacity		kg	1600		
	4		Load centre		mm	500		
	5		Lifting height		mm	3000		
	6		Free lifting height		mm	0		
Dimensions	7		Fork size		T×W×L	mm	920×100×35	
	8		Tilting angle		F/R (α°/β°)	Deg	3°/6°	
	9		Overall Dimension		Length (to forkface)		mm	1919
	10				Width		mm	1078
	11				Height when mast lowered		mm	1975
	12				Height when mast extended		mm	4010
	13		Height to safeguard		mm	1952		
	14		Turning radius		mm	1544		
	15		Front overhang		mm	376		
	16		Tread		F/R	mm	930/0	
17		Ground clearance Min.		mm	85			
18		Wheelbase		mm	1245			
19		Fork spread		Min./Max.	mm	200/890		
20		Working aisle width with pallet(Ast)*		1000×1200 crossways		mm	3245	
21				800×1200 lengthways		mm	3370	
Performance	22		Speed		Travel(Laden)		km/h	12
	23				Travel(Unladen)		km/h	13
	24				Lifting(Laden)		mm/s	280
	25				Lifting(Unladen)		mm/s	440
	26				Gradeability		Laden	
27		Unladen		%			10	
28		Service weight		Include battery box	kg	3240		
29		Tyre		Front×2			18×7-8	
30				Rear×1			18×7-8	
31		Motor		Driven motor		kw	4.5	
32				Pump motor		kw	11	
33		Battery		Standard(Optional)	V/Ah	48/400		
34		Operating pressure for attachment			Mpa	14.5		

Type	Model	Max. fork height	Overall height			Free lift		Front Overhang	Tilt range		Capacity
			Lowered	Extended		Without backrest	with backrest		FWD	BWD	load capacity at 500mm
				Without backrest	With backrest						Single tyre
		mm	mm	mm	mm	mm	mm	Deg	Deg	kg	
2-stage mast	BM250	2500	1725	3010	3480	0	0	371	3	5	1600
	BM270	2700	1825	3210	3680	0	0	371	3	5	1600
	BM300	3000	1975	3510	4010	0	0	371	3	5	1600
	BM330	3300	2125	3810	4280	0	0	371	3	5	1600
	BM350	3500	2225	4010	4480	0	0	371	3	5	1600
	BM370	3700	2325	4210	4680	0	0	371	3	5	1600
	BM400	4000	2525	4510	4980	0	0	371	3	3	1600
	BM425	4250	2650	4760	5280	0	0	371	3	3	1500
	BM450	4500	2775	5025	5480	0	0	371	3	3	1400
	BM500	5000	3025	5525	5980	0	0	371	3	3	1250
full free 2-stage mast	BFM250	2500	1725	3010	3465	1230	725	371	3	5	1600
	BFM270	2700	1825	3210	3665	1330	825	371	3	5	1600
	BFM300	3000	1975	3510	3965	1480	975	371	3	5	1600
	BFM330	3300	2125	3810	4265	1630	1125	371	3	5	1600
	BFM350	3500	2225	4010	4465	1730	1225	371	3	5	1600
	BFM370	3700	2325	4210	4665	1830	1325	371	3	5	1600
	BFM400	4000	2525	4510	4965	2030	1525	371	3	3	1600
	BFM450	4500	2775	5010	5465	2280	1775	371	3	3	1400
	BFM500	5000	3025	5510	5965	2580	2025	371	3	3	1250
	BFM550	5500	3325	6010	6465	2830	2325	371	3	3	1150
Full free 3-stage mast	BTFM360	3600	1725	4110	4580	1210	705	371	3	3	1600
	BTFM400	4000	1850	4510	4980	1335	830	371	3	3	1600
	BTFM435	4350	1975	4860	5330	1425	995	371	3	3	1500
	BTFM450	4500	2025	5010	5480	1475	1045	371	3	3	1400
	BTFM480	4800	2125	5310	5780	1575	1145	371	3	3	1300
	BTFM500	5000	2225	5510	5980	1675	1245	371	3	3	1250
	BTFM550	5500	2390	6010	6480	1840	1410	371	3	3	1150
	BTFM600	6000	2575	6510	6980	2025	1595	371	3	3	1050
	BTFM650	6500	2790	7010	7480	2240	1710	371	3	3	900

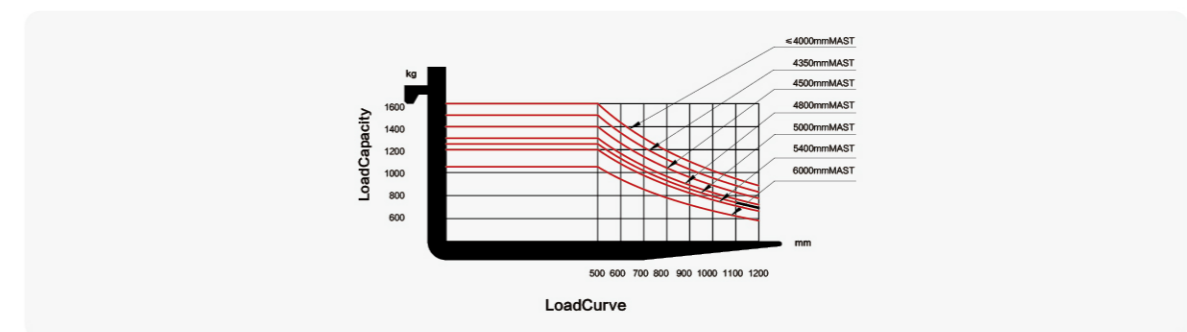



a=200 mm safety clearance  
 $Ast = a + ⑭ + ⑮ + \sqrt{W^2 + (B/2)^2}$

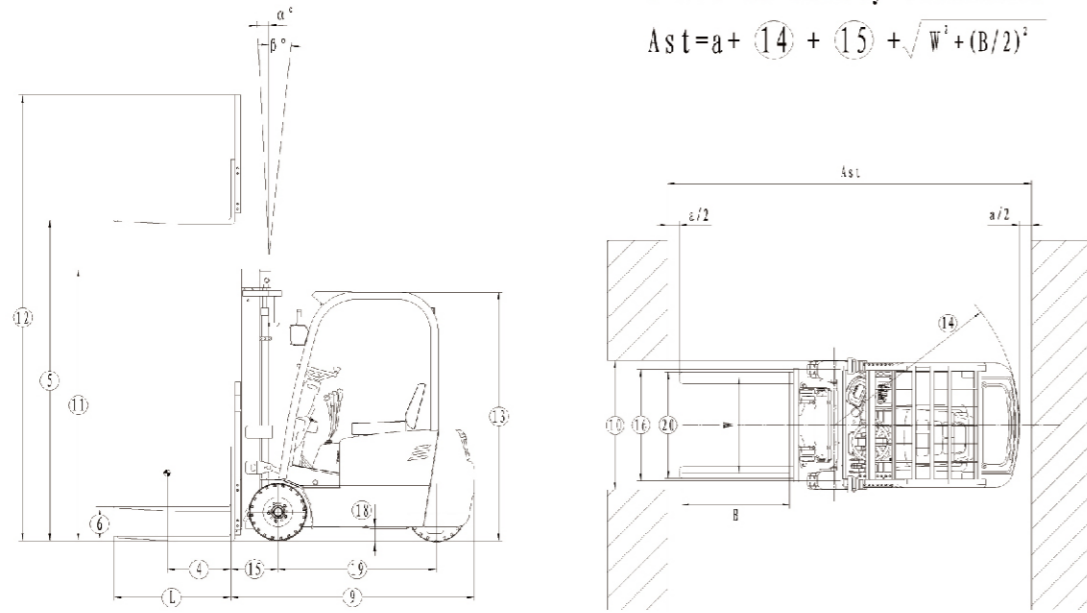

REAR DRIVE  
 3-WHEEL  
 FORKLIFT 1.6T  
**M SERIES**



## COMPANY MEMORABILIA

2005	Dec	Zhejiang Maximal Forklift Co., Ltd was officially established.
2006	Oct	M series forklifts displayed at the 100th Canton fair.
2007	Nov	Maximal phase I project of the new factory finished.
2008	Jan	Structure of electric forklift was further optimized.
	Nov	Maximal was appointed by the General Logistics Department of the People's Liberation Army(PLA) to be supplier for Military Equipment.
2009	Mar	4.0T&5.0T and 8.0-10.0T diesel forklift were launched to enrich M Series.
	May	Maximal started to prepare the R&D of 16.0-18.0T diesel forklift.
2010	Nov	The first 4.5T electric forklift and 25.0T heavy duty forklift were displayed on Shanghai CeMAT.
	Dec	Maximal and Military Transportation University reached
2012		Maximal was honored as "state-level high-tech enterprise".
2013	May	Maximal 2WD 2.5/3.5T Rough Terrain forklift was launched to the market.
	July	Maximal Empty Container Handler was officially developed.
2014	Jun	Maximal electric stackers & pallet trucks were put into market.
	Aug	Maximal 2WD Rough Terrain forklift were extended to 4.0/5.0T.
	Dec	Maximal phase II project was finished.
2015	May	Maximal 3.5T 4WD Rough Terrain forklift was successfully developed. First Reach Stacker successfully was sold in domestic market.
2016	July	Maximal won the Chinese well-known trademark.
	Oct	1.8-3.5T C. 4WD Hydraulic rough terrain forklift was successfully launched.
2018	July	3.5-4.5T Sider-loader forklift was lanched; Electric forklift with lithium battery started to be developed; 1.6-2.5T A series Reach truck was lanched.
	June	<b>Hyster-Yale and Maximal officially completed its acquisition, Zhejiang Maximal Forklift Co., Ltd. renamed to Hyster-Yale Maximal Forklift (Zhejiang) Co., Ltd, began a new start.</b>